

Flight deck systems

Pre FMS → THE AOM

The AOM (Aircraft Operating Manual) contains and describes all aircraft performance-related data needed for the operation of the aircraft. → Flight crew must interpolate data from the AOM tables to find the optimal settings for the appropriate flight condition

Optimization of flight management is difficult with the AOM only and it can also lead to high pilot workload

Flight management system

Drivers

Non-technical drivers

- **Quantifiable economic benefits:** optimize flight performance to minimize cost.
- **Pilot workload**
- **Growth of air traffic:** more stringent air traffic control related requirements

Technical drivers

- **Availability of accurate navigation sources :** GPS, INS
- **Availability and affordability of very powerful and reliable computer systems:** storing and manipulating very large amounts of data
- **Ability to connect the various subsystems:** providing data to the FMS by an efficient digital data bus system

Block diagram

FMS=Flight Management Computer + Flight Data Storage Unit + Control Display Unit

Input are sensors ; output is autopilot and displays

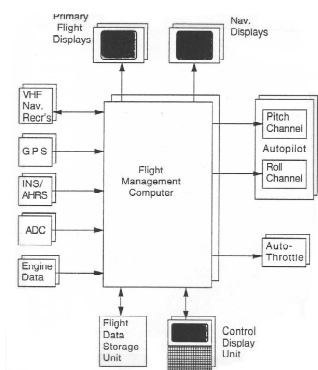

Tasks of the FMS

1 Flight Planning

Provides a computerized flight planning aid to the pilot (through CDU) and enables major revisions of the flight plan to be made in flight.

It uses the FDSU for this. → Updated every 28 days

2 Navigation and Guidance

- Combines data from all navigation sources to derive the best estimate of aircraft position and velocity sensor fusion
- Selects and automatically tunes the nav aids specified in flight plan and makes navigation computation
- Computes ground speed, track, wind direction and wind velocity
- Provides both lateral and vertical guidance to autopilot
- Provides guidance to automatic Thrust Control Computer (Auto Throttle)

3 Optimization and Performance prediction

Selects speed, altitude and engine power settings during all phases of flight taking into account flight plan, prevailing conditions and optimization of the operation of the aircraft

Optimization → integrates knowledge about

- Aircraft type and weight (including fuel weight)
- Engine type and performance characteristics
- Aircraft center-of-gravity position
- Wind, air temperature
- Flight level and flight plan constraints
- Aircraft status (speed; height; Mach number)
- Company route index
- **Yields optimal time referenced flight plan**

Performance in terms of

- Time, altitude, fuel, wind at each waypoint of flight plan
- 'engine out' performance
- Climb and descent computations
- Altitude and time markers
- 3-D and 4-D performance
- Arrival times (for ATC)