

**Question: Describe the working principle of the magnetometer**

The magnetometer is based on the idea that the magnetic flux moving through a coil depends on the orientation of the with respect to the magnetic field lines of the earth:

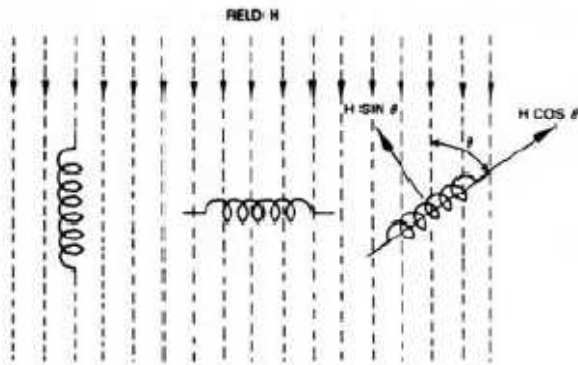

In total the magnetometer looks as follows:

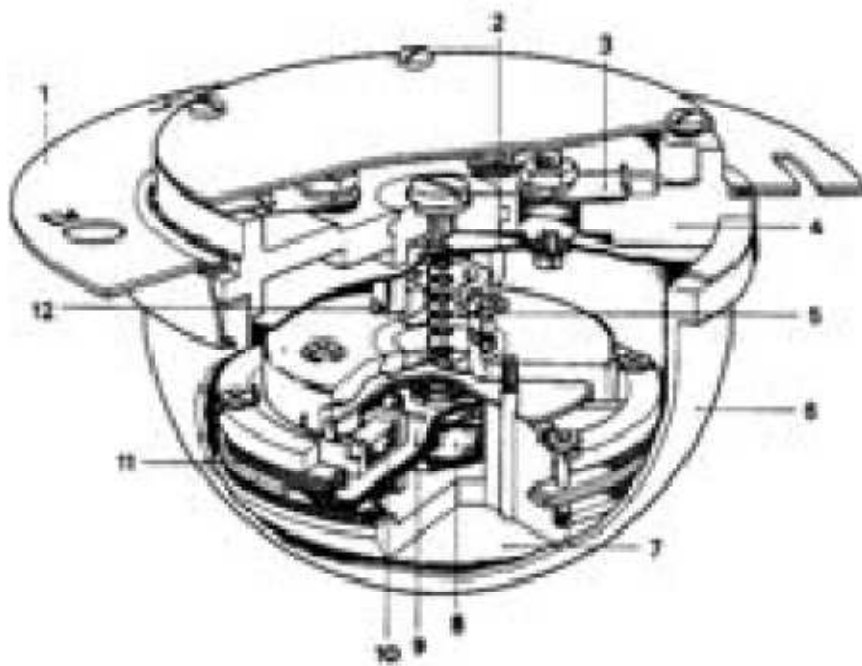

It consists of three spokes which share a single exciter coil. The complete suspend in order to ensure that only the horizontal component of the magnetic field is measured. When zooming down to one of the spokes the following sketch can be made:

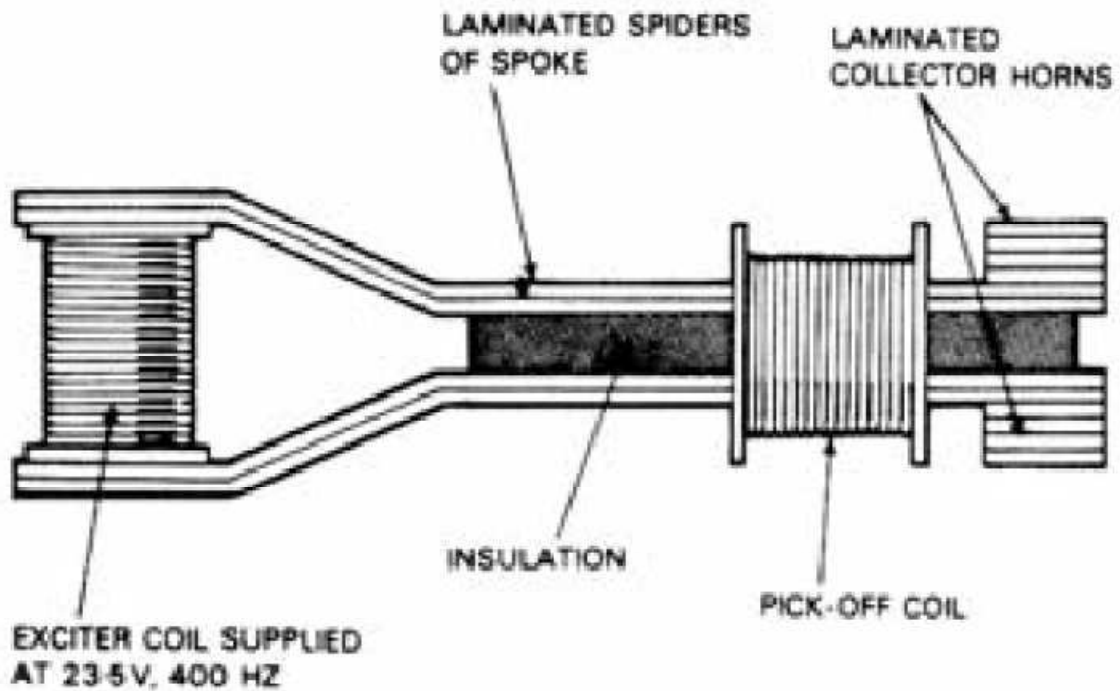

What basically is done is that the exciter coil induces an alternating current which magnetizes both the upper and lower leg, but then reversed polarity. Hence in the absence of an external magnetic field the resulting total flux will be zero:

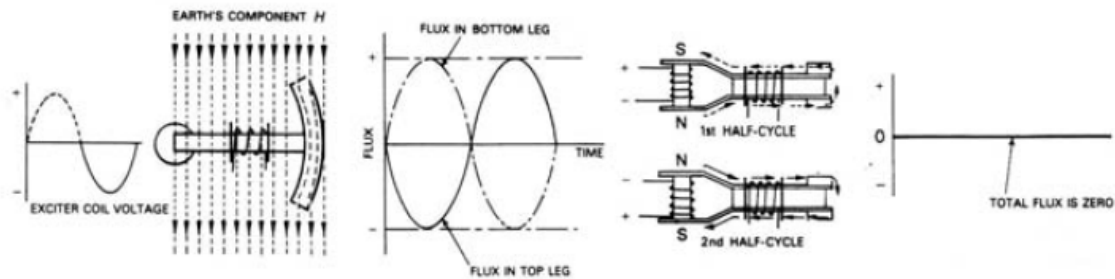

However with the inclusion of an external field (that of the earth for example), changes in the total flux can be observed. This change in flux is caused by the saturation of the permalloy used. When a magnetizable material is fully saturated: the material is completely magnetized and a stronger magnetic force has no effect on the magnetic flux density. This property is illustrated in this figure:

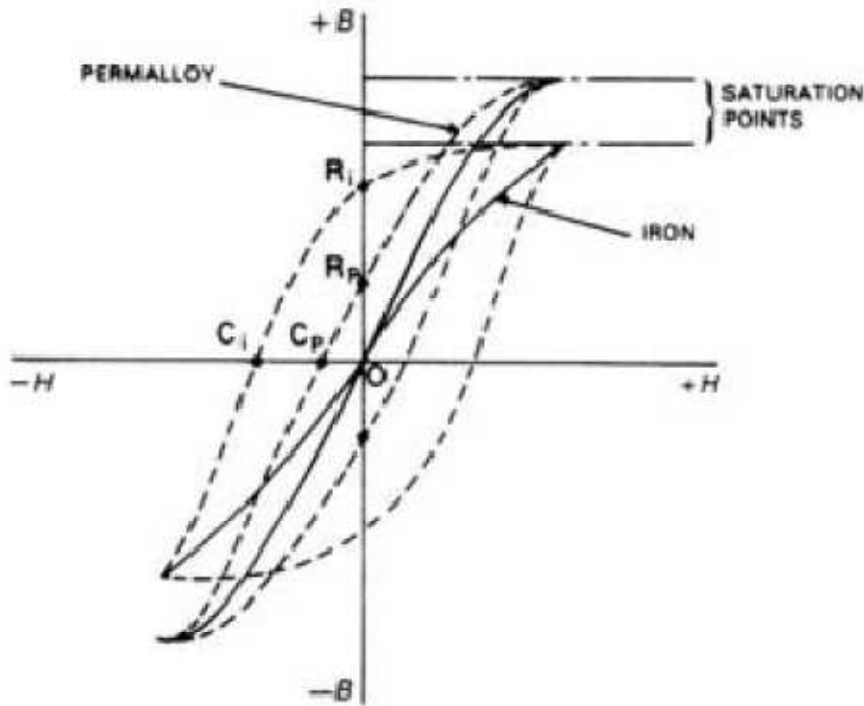

Due to saturation the total flux will look as follows:

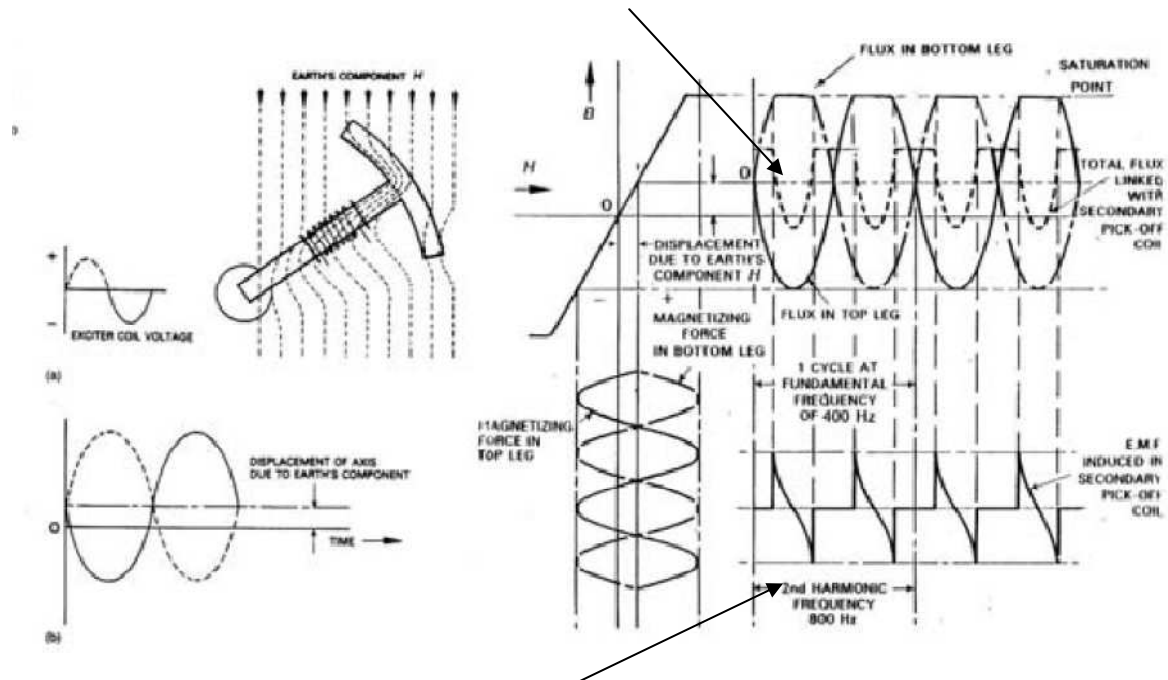

A change in flux induces a voltage in the pick-off coil, the magnitude of the voltage is directly related to the orientation of the magnetic field with respect to the heading of the aircraft.

However there is still ambiguity, this ambiguity is solved with the *knowledge of knowing what type of input signal is used* and the three spokes.